

# Analyzer Fundamentals

pH - Oxidation Reduction Potential  
Dissolved Oxygen - UV Nitrate

# Agenda

- pH
- Oxidation Reduction Potential
- Dissolved Oxygen
- Nitrate

# pH

- **The** most important parameter
- Hydrogen ion activity
  - How acidic or basic (alkaline)
- Online and lab methods the same
  - Combination probe:
    - Measuring half cell
    - Reference half cell

# Combination pH Method

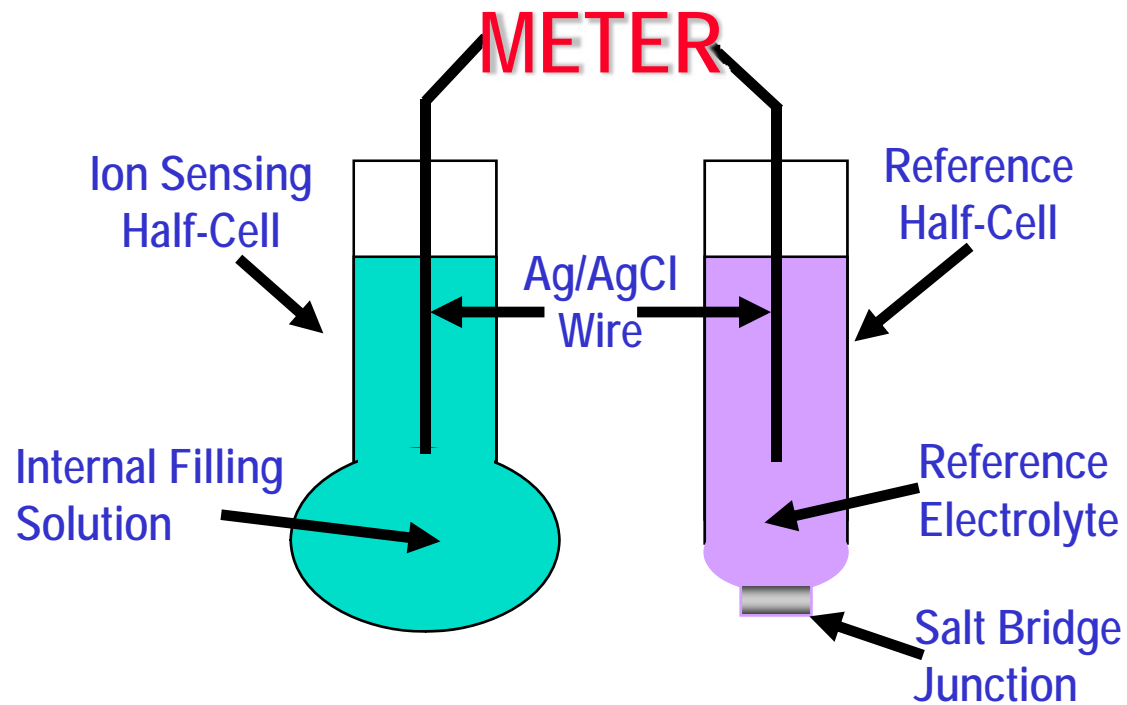

# Differential pH Method

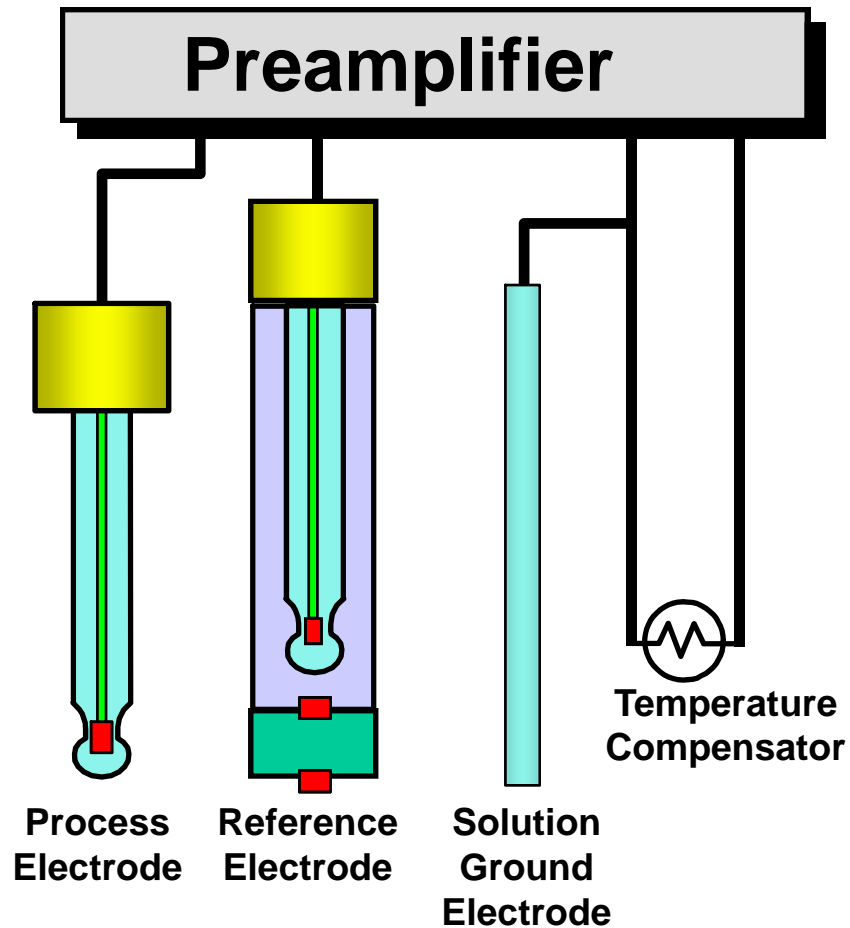

# ISFET Solid State pH Method



# ISFET Method

Gate insulator:

Thickness: about 0.1  $\mu\text{m}$

Material:  $\text{Ta}_2\text{O}_5$  (tantalum oxide)

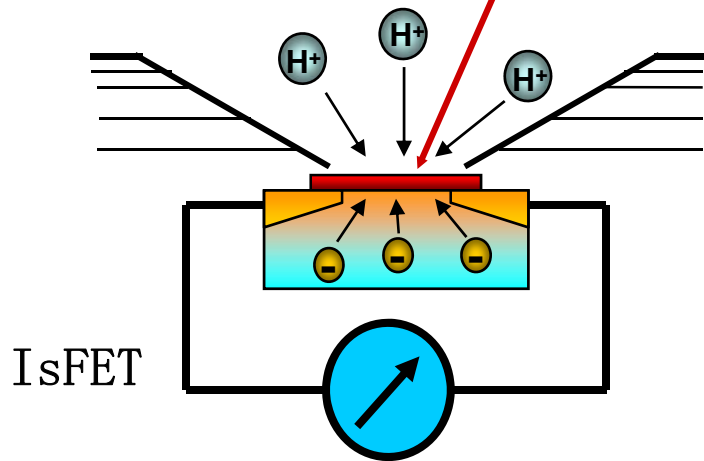

The insulator is an amphoteric material (acting as acid or base), thus surface charges are occurring by the reversible reaction with  $\text{H}^+$  resp.  $\text{OH}^-$  -ions

Important: Contrary to the glass electrode no charges are transported through the insulator, the effect is purely electrostatic

# Oxidation Reduction Potential

- ORP or Redox
- Indication of a solution's ability to oxidize or reduce another solution
- Chlorinated water: high ORP (+700mV)
- Bisulfite water: low ORP (-700mV)
- Methods similar to pH measurement

# Oxidation Reduction Potential

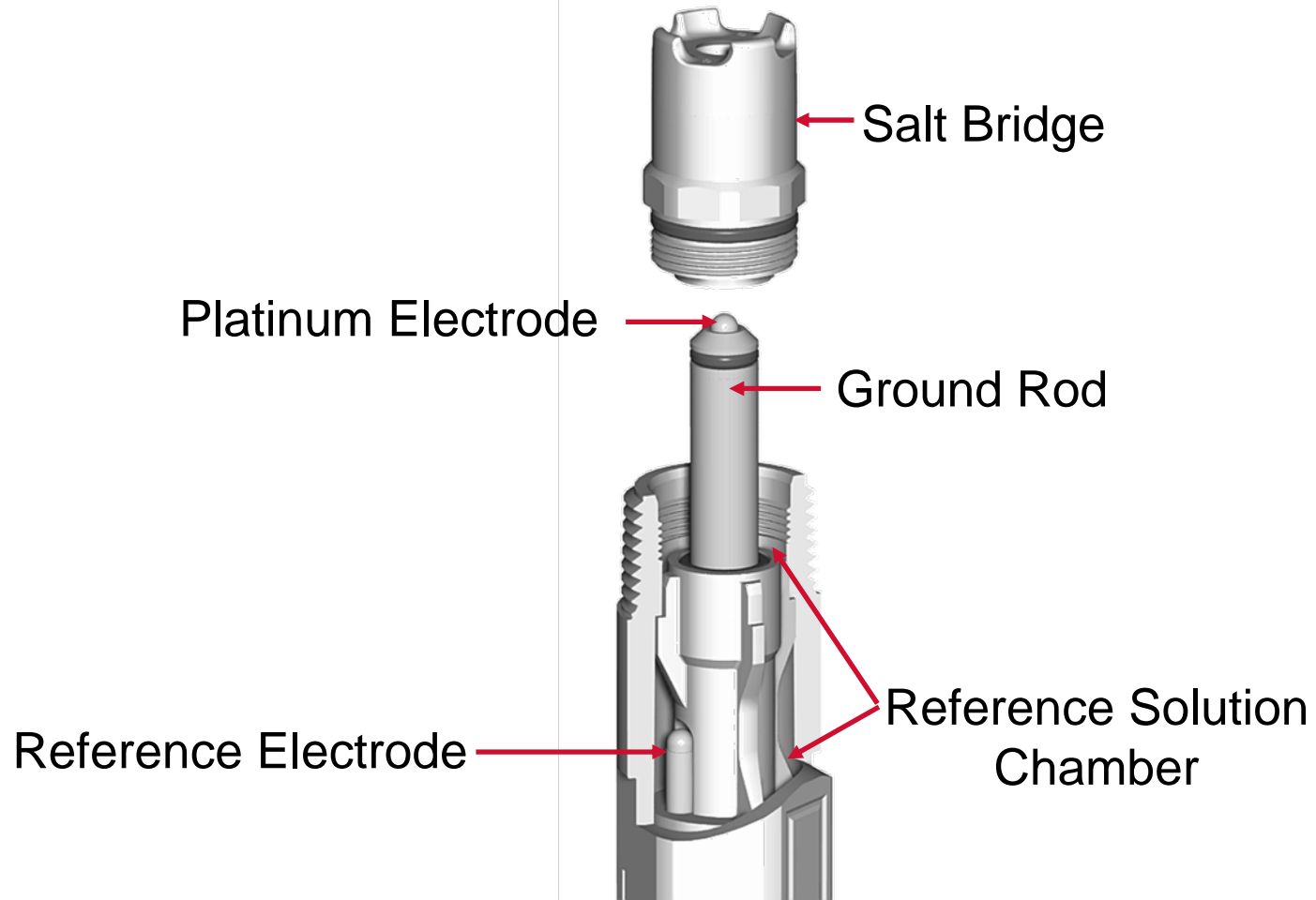

# Dissolved Oxygen & ORP in an SBR

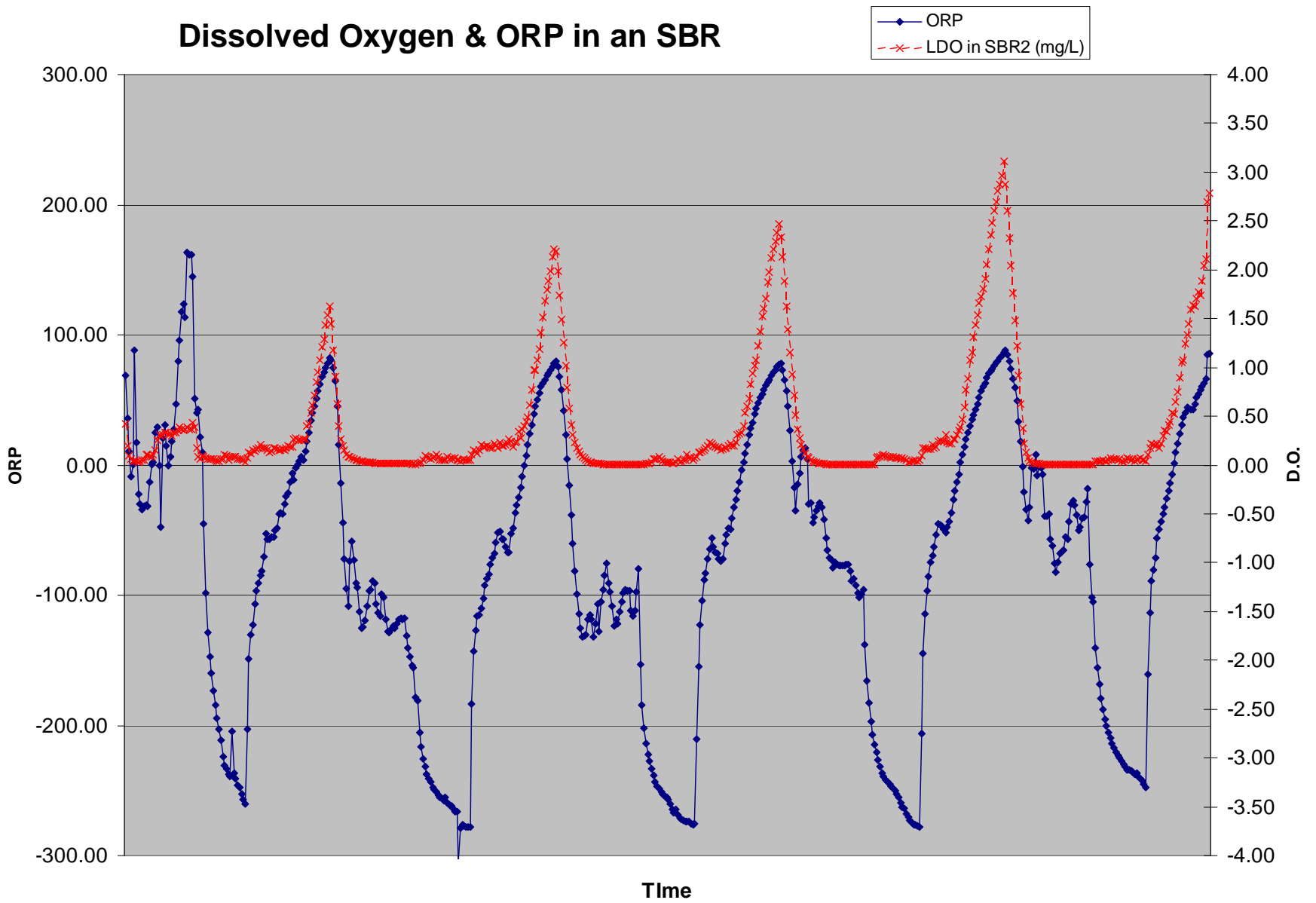

# Dissolved Oxygen

- Lab and online use same methods
  - Exception: Winkler method
- Note: DO = Residual Dissolved Oxygen



# Dissolved Oxygen

- Three ways to measure dissolved oxygen:
  - Galvanic\*
  - Clark (Polarographic)\*
  - Luminescence (Optical)\*\*

\*EPA Approved or Accepted \*\*Acceptance varies by region

# Galvanic Method

- A galvanic cell operates much like a battery!



# Galvanic Method

- Two electrodes of dissimilar metals are immersed in a filling solution.

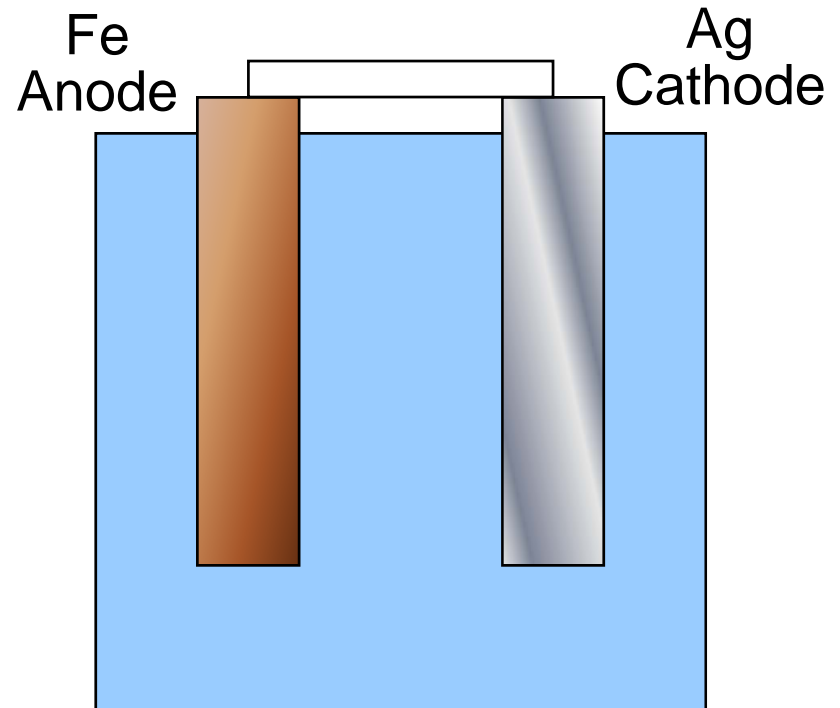

# Galvanic Method

- A spontaneous reaction occurs between the two metals
- Oxygen enters the cell through a membrane

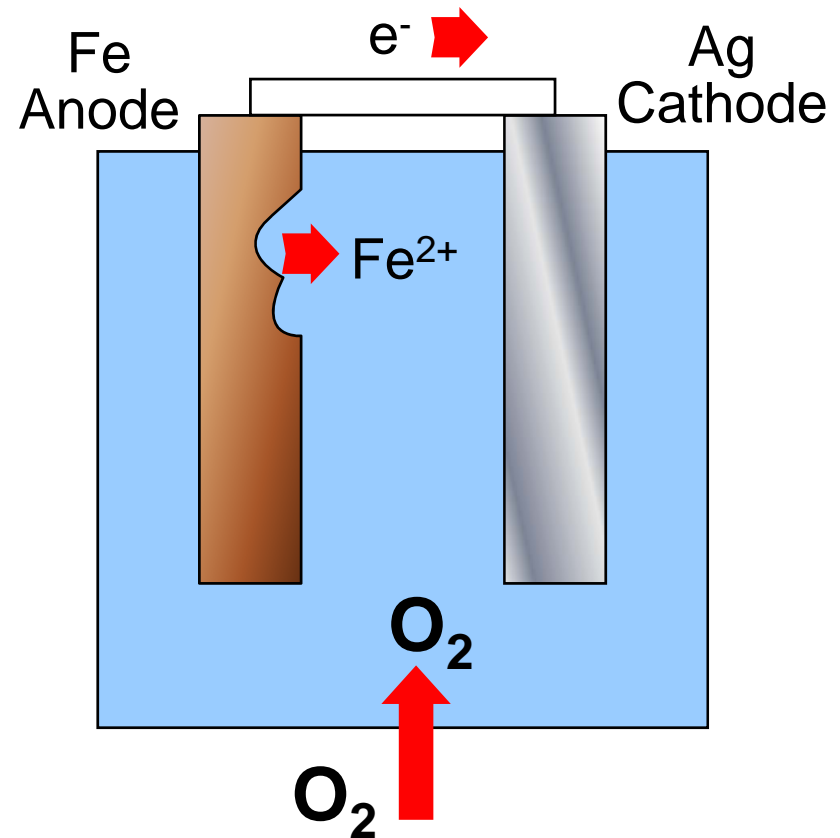

# Galvanic Method

- Oxygen is reduced to hydroxide at the cathode
  - 4 electrons released at the anode for each molecule of oxygen destroyed

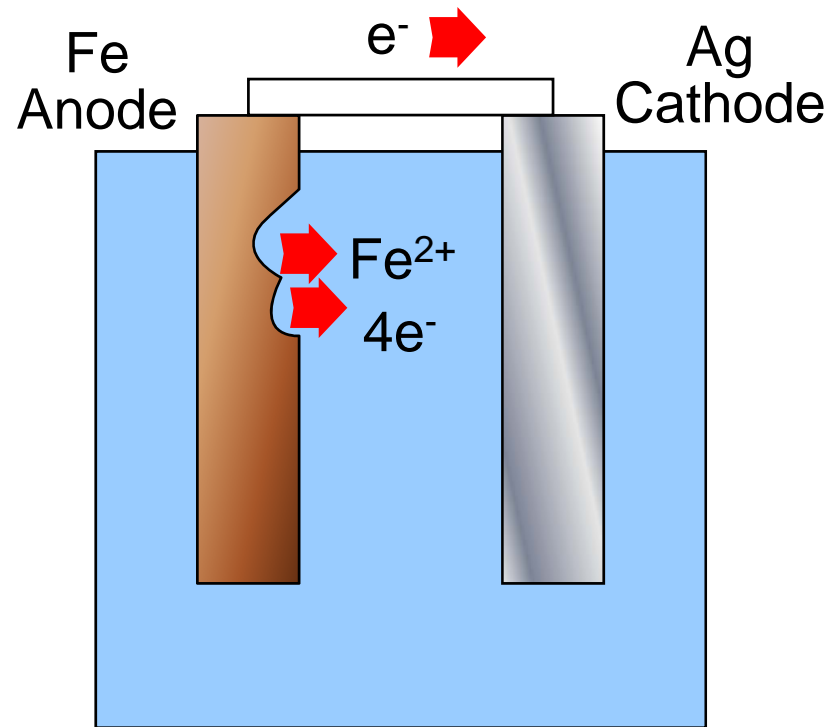

# Galvanic Method

- Number of electrons (or voltage) is proportional to DO concentration

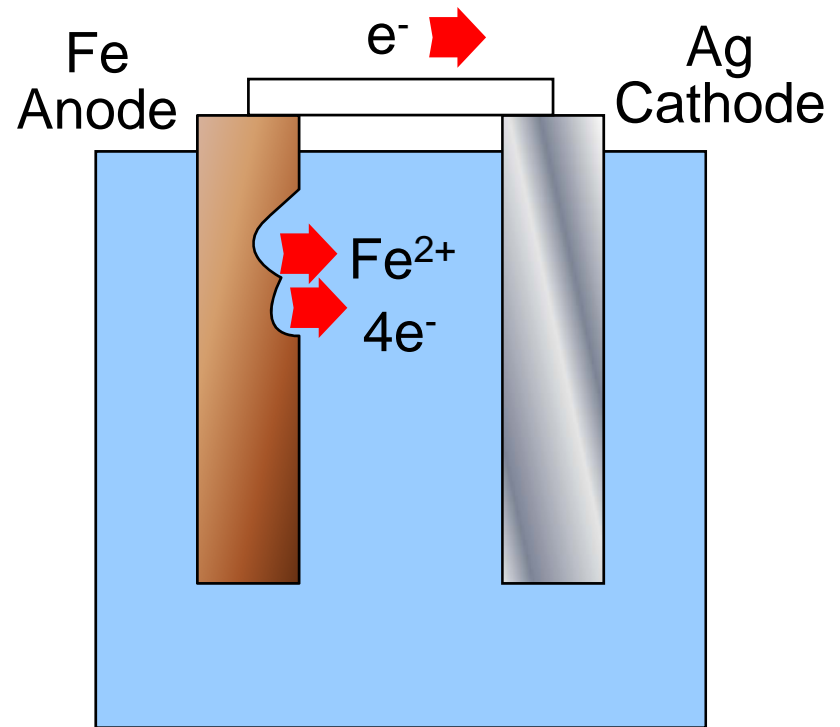

# Polarographic Method

## 4 basic components:

1. Anode
2. Cathode
3. Electrolyte solution
4. Membrane

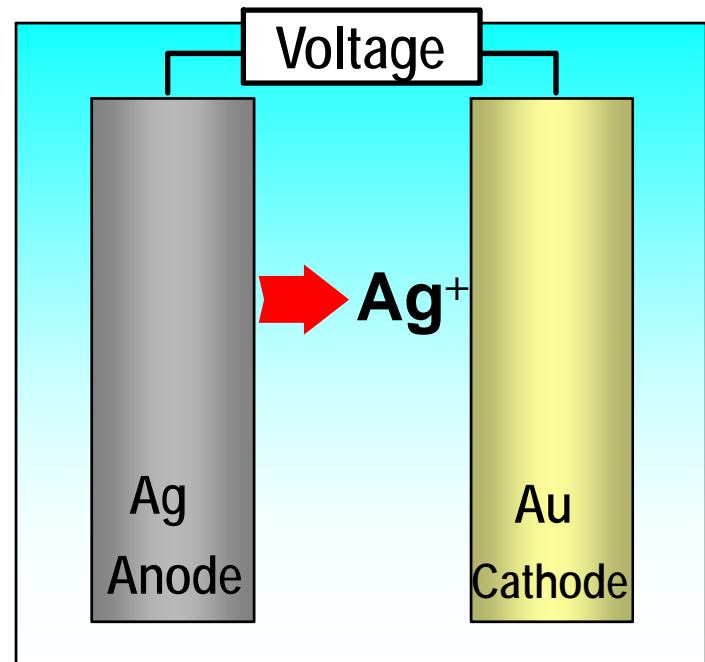

# Polarographic Method

- A constant polarizing voltage is applied across the electrodes.

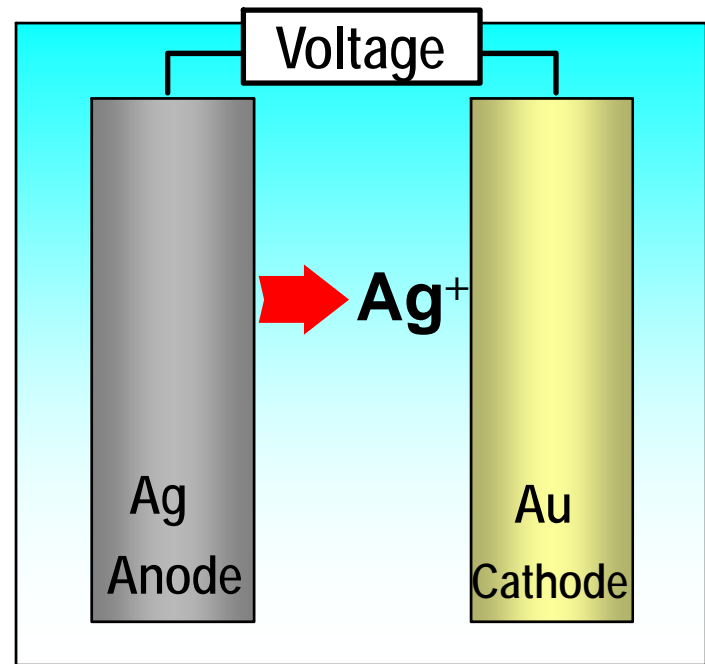

# Polarographic Method

- As oxygen permeates the membrane, it is reduced at the cathode
- The current (amperage) created is directly proportional to the dissolved oxygen concentration

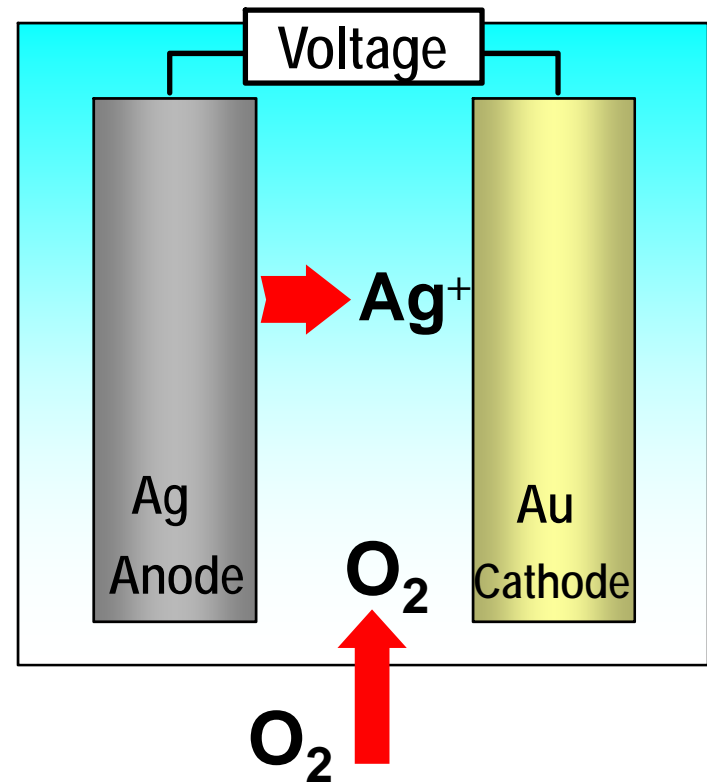

# Luminescent Method

- A sensor is coated with a luminescent material
- Blue light from an LED strikes the luminescent chemical on the sensor
- The luminescent chemical instantly becomes excited

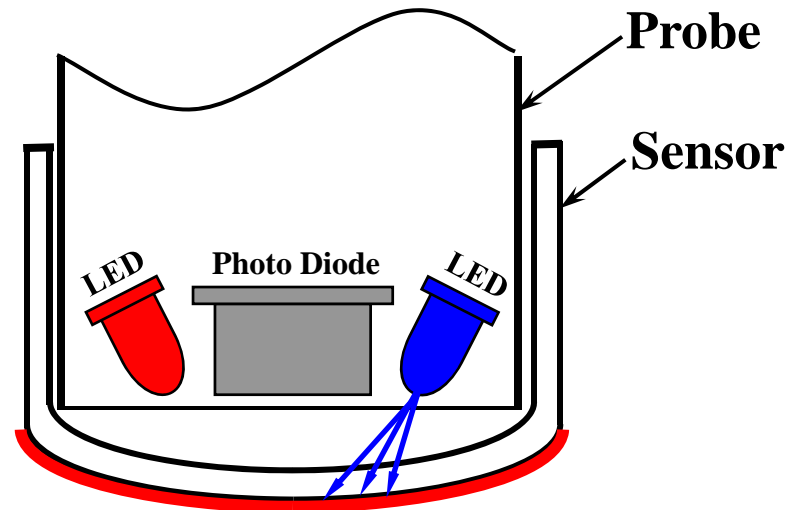

# Luminescent Method

- As the excited chemical relaxes, it releases red light
- Oxygen “steals” the energy from the luminophore
- The time it takes for the chemical to return to a relaxed state is measured

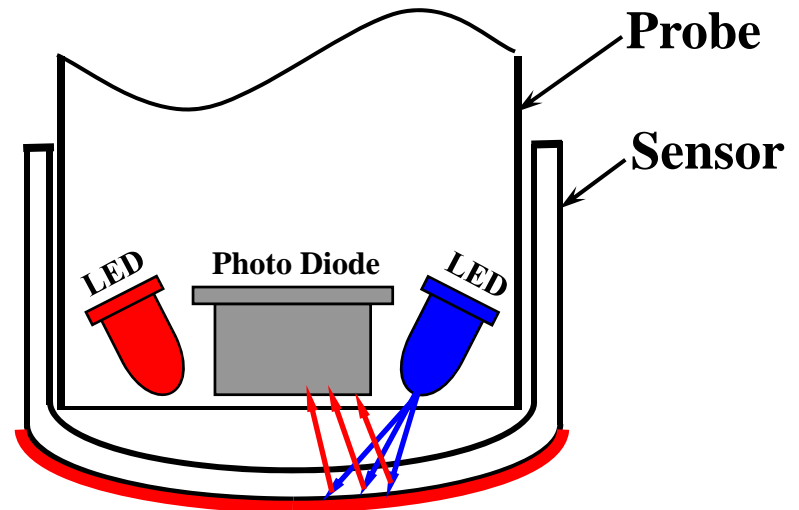

# Luminescent Method

- The higher the oxygen concentration, the less red light that is given off by the sensor

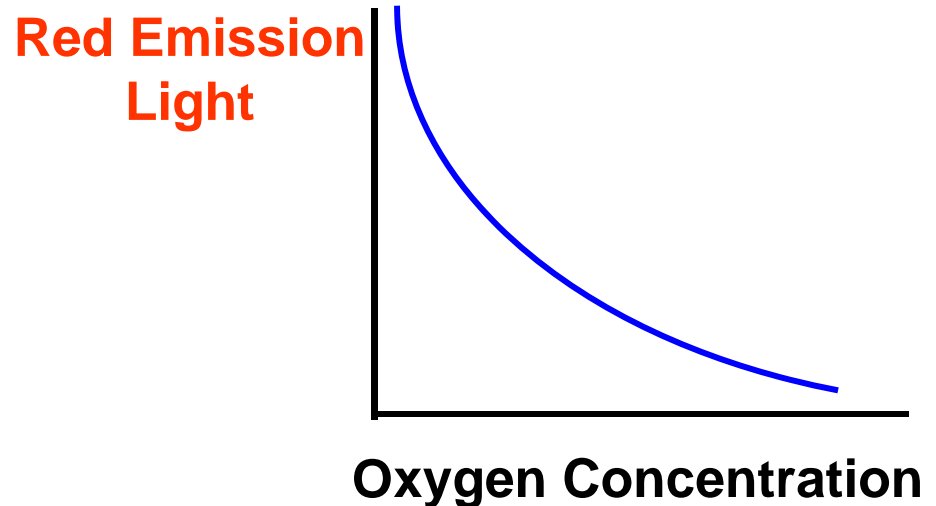

# Luminescent Method

- A red LED flashes between the blue LED pulses
- The red LED acts as an internal standard making calibrations unnecessary

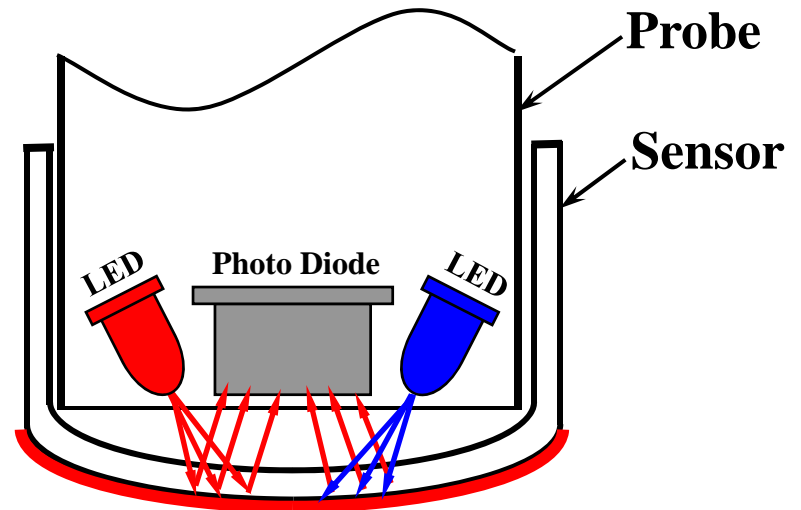

# Significant Findings

- Narayanan et. al., 2007\*
  - Bio-P: Aerobic uptake was critical step limiting process performance
  - Uptake was robust when aeration supply to the initial aerobic zones was not limiting
  - Strong initial uptake is key to good BPR performance

# UV Nitrate Method

- **In-line**
- **No reagent**
- **No moving parts**

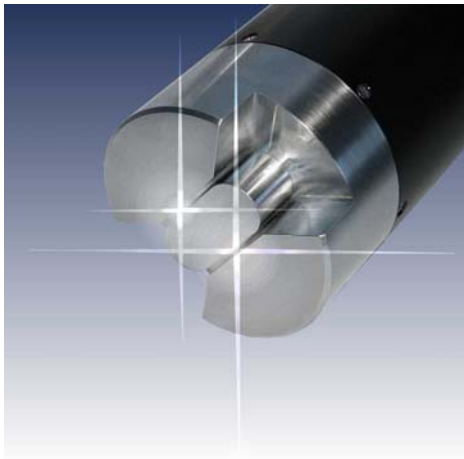

# UV Nitrate Method

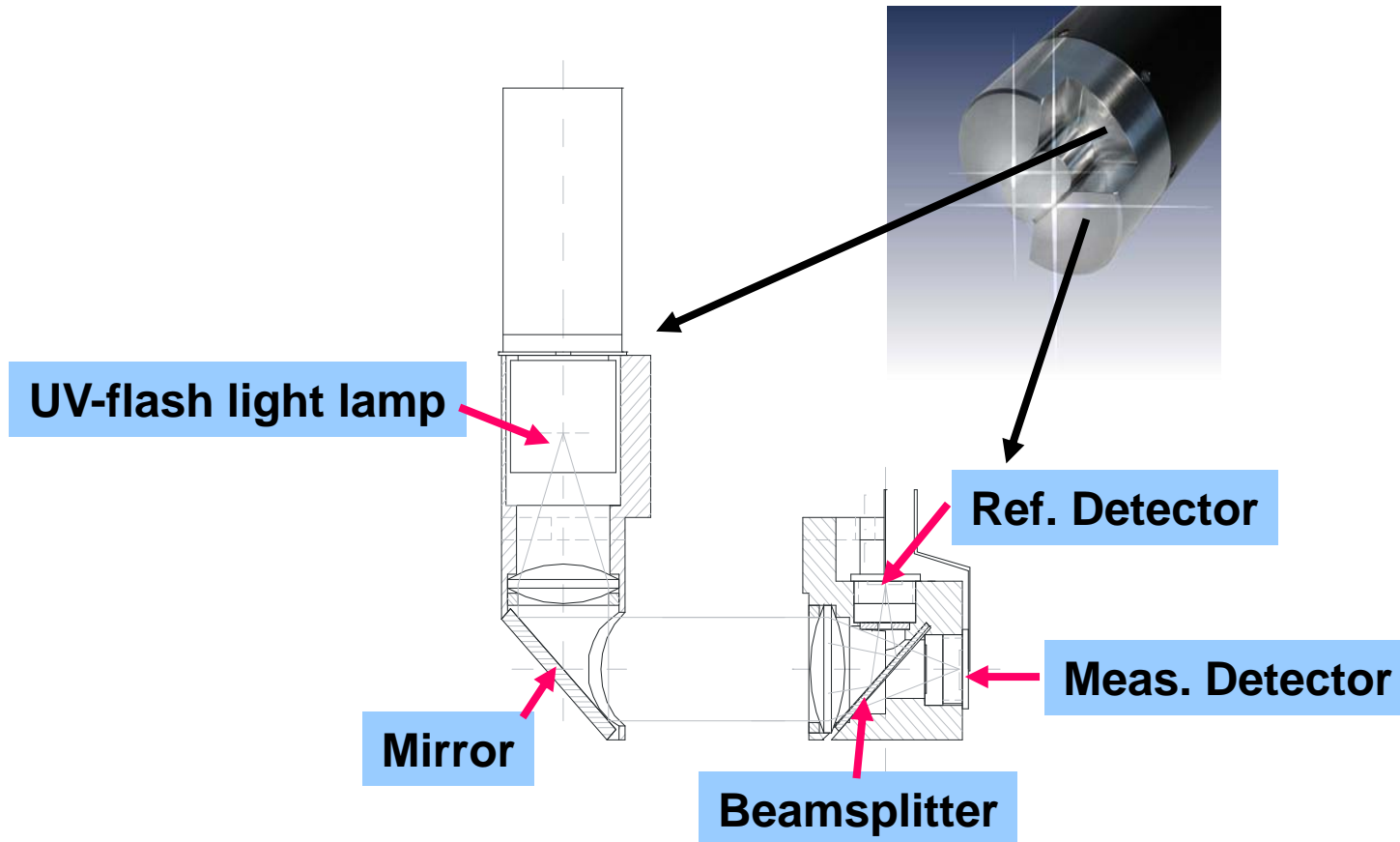

# Multi-parameter

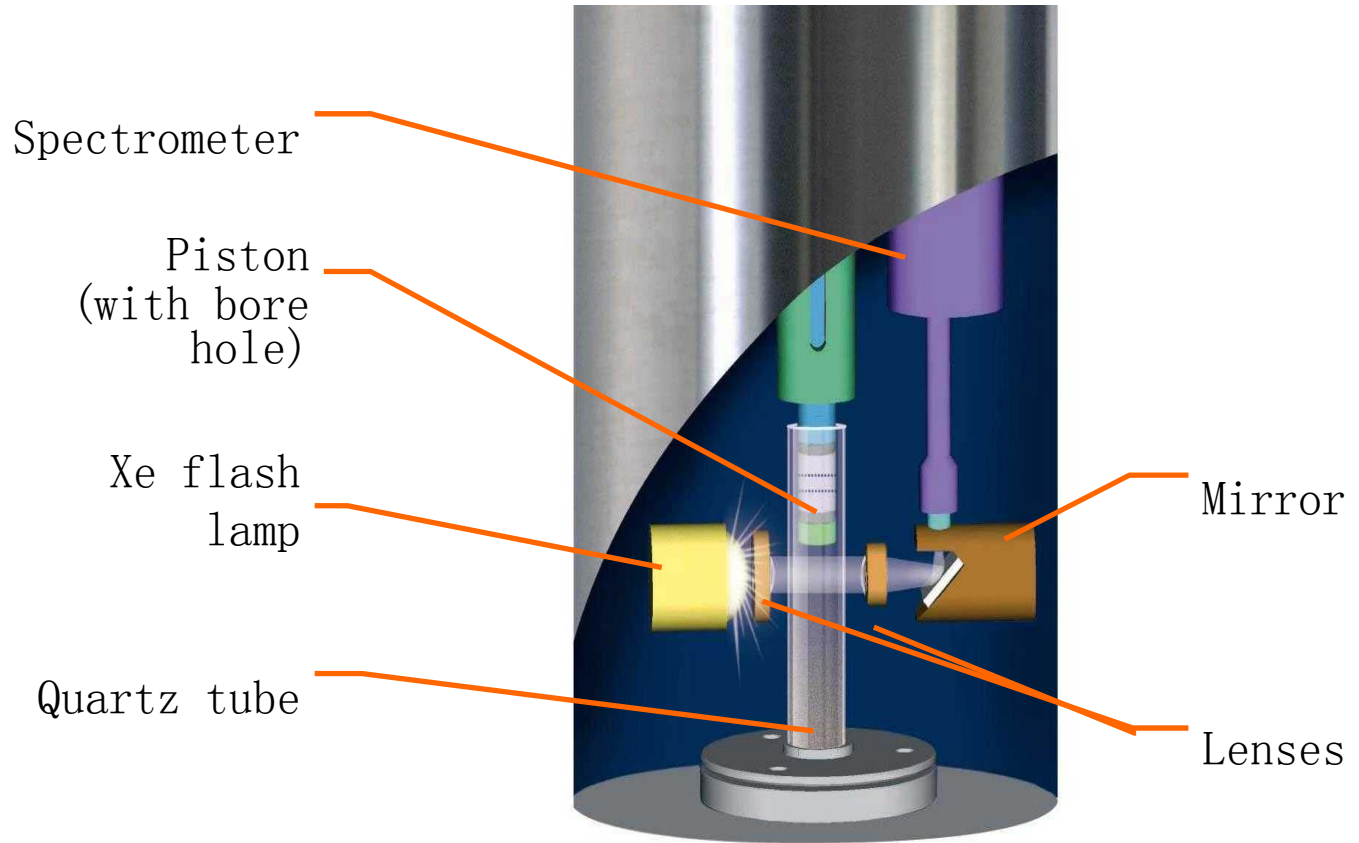

Nitrate, Dissolved Organics & (SVI, TSS)

# Multi-parameter

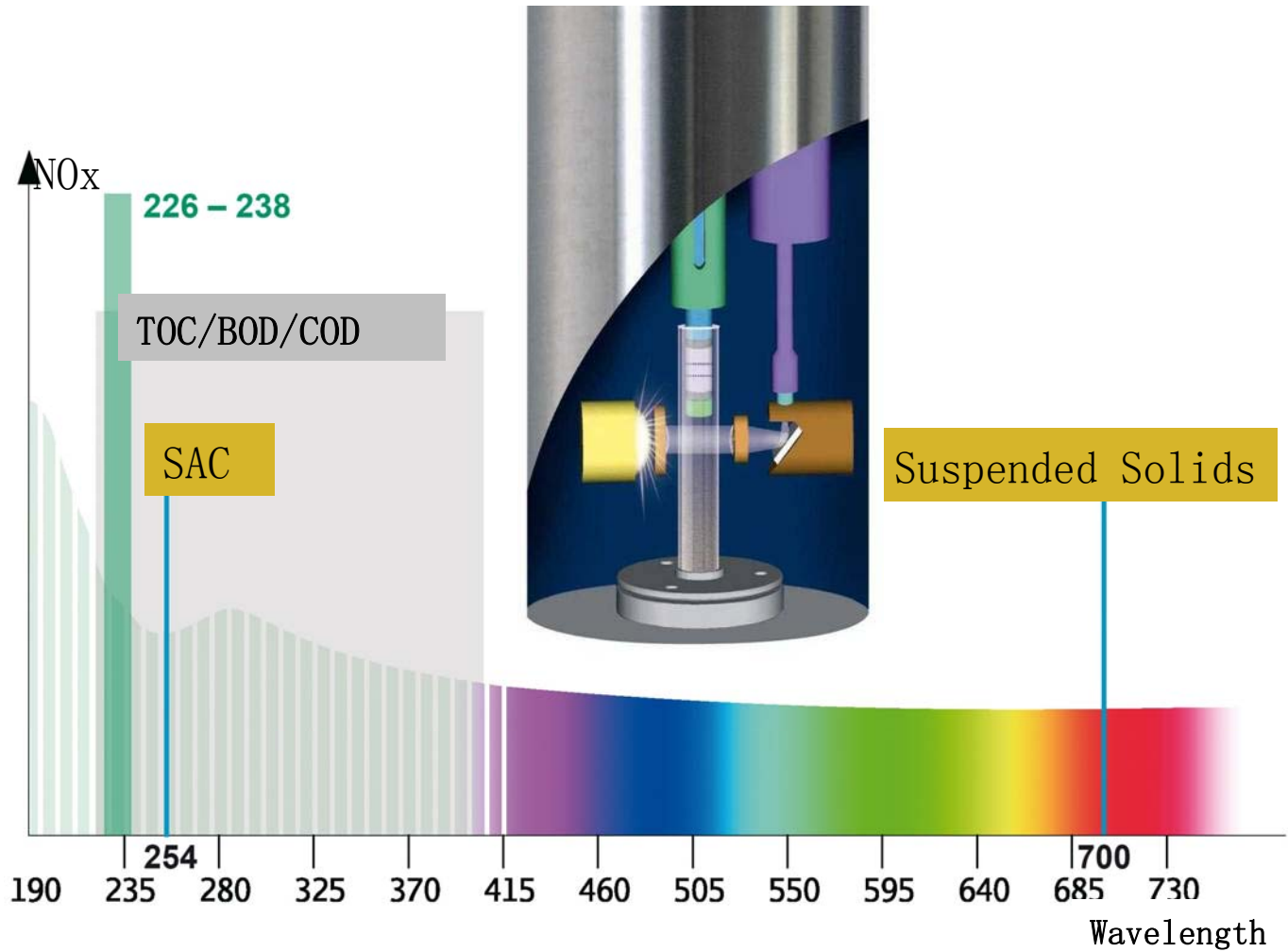

# UV Nitrate Method



- Several measuring ranges depending on application
  - MDL: 0.1mg/L
  - +/- 2% of measured value or 0.1mg/L
- Self Cleaning
- Measurement Interval
  - 1 to 30 minutes (user-selectable)

# UV Nitrate Method

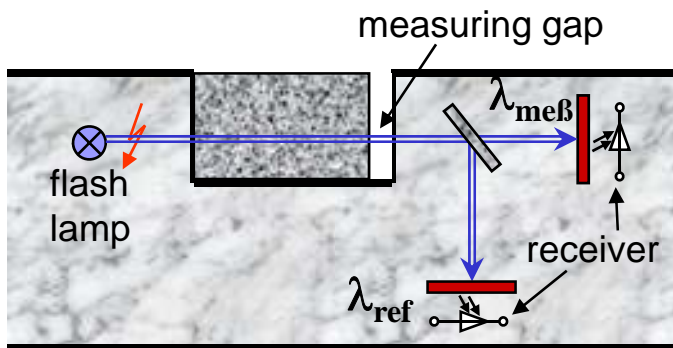

- Two wavelengths of ultraviolet light (210nm & 350nm)
- 210nm absorbance: nitrates, nitrites, organics, and particles
- 350nm absorbance: organics and particles
- $210 - 350 = \text{NO}_x\text{-N}$

# UV Nitrate Method

## • Application Note

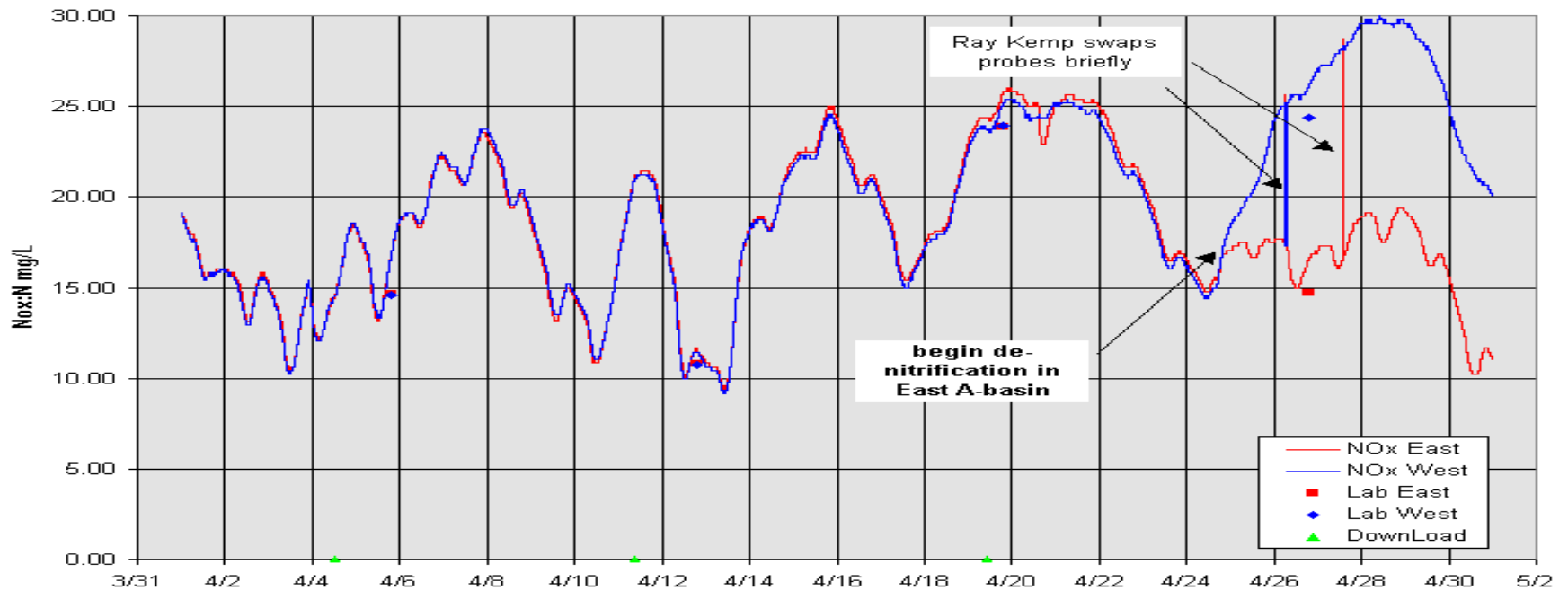

# UV Nitrate Method

## • Application Note

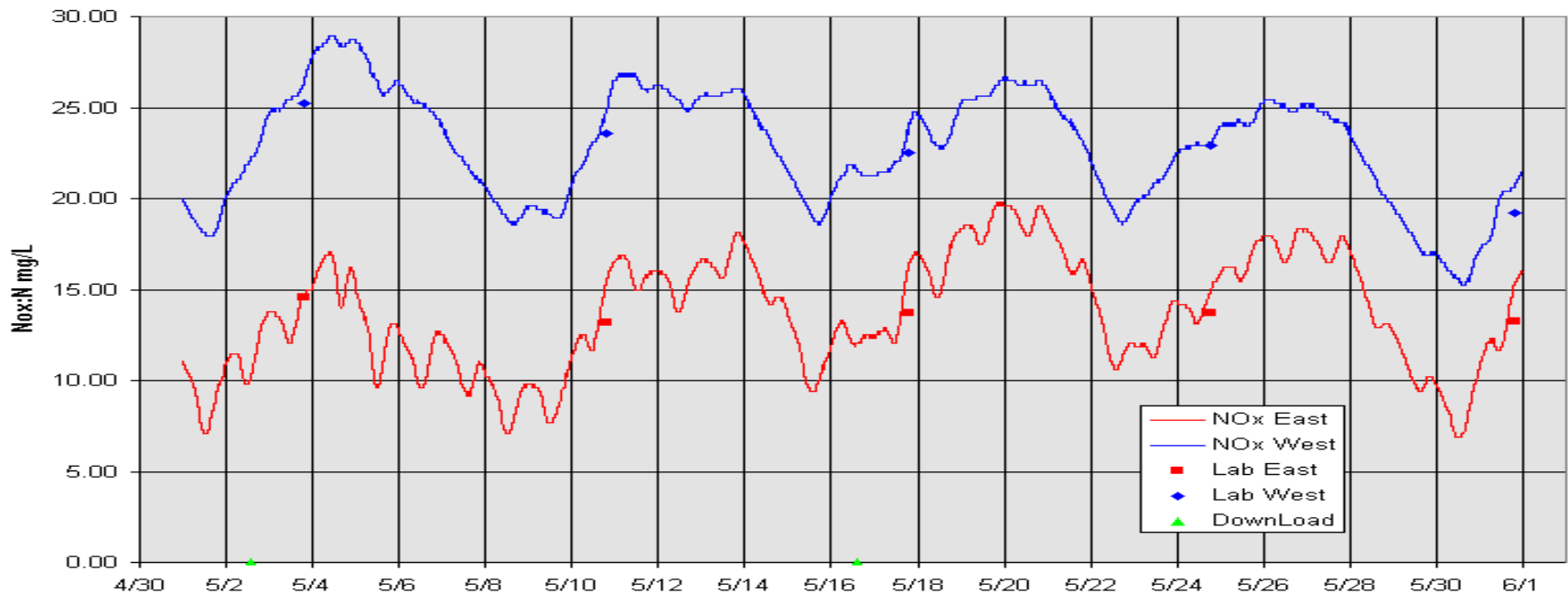

# Analyzer Fundamentals

pH - Oxidation Reduction Potential  
Dissolved Oxygen - UV Nitrate